

PISTER TILTROTATOR PT

The robust, excavator arm-mounted all-rounder
for use with all attachments

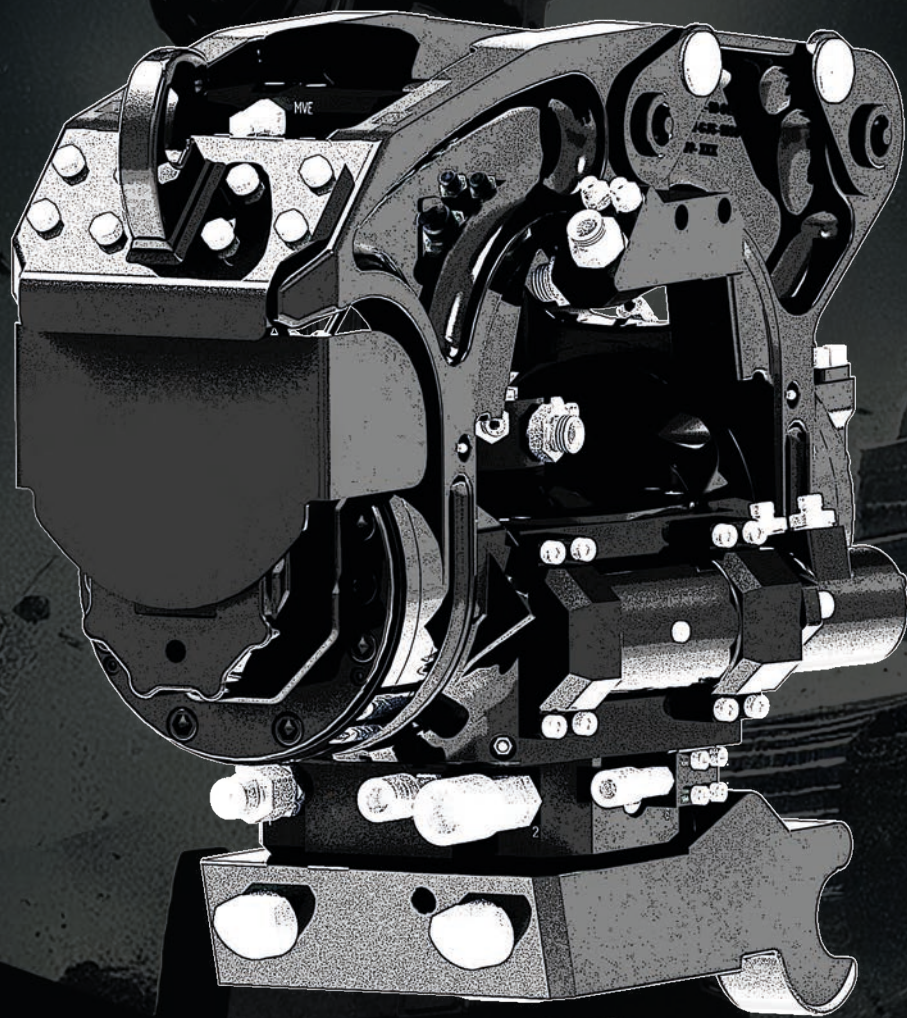

PISTER[®]
Kugelhähne

PISTER TILTROTATOR PT

The flexible joint for your excavator

BENEFITS

of the all-rounder amongst tiltrotators

The rugged multifunctional system maximises your excavator's possible applications by adding two functions: it allows both alternating and simultaneous pivoting as well as infinite rotating of your attachments. The wide range of motion in the joint at the end of the excavator arm allows you to position your attachments with high precision without having to manoeuvre the excavator a lot.

This added flexibility helps optimise utilisation and unlocks new applications for your attachments. On the other hand, it maximises their operating range and, by precision positioning of your attachments, allows for much more rapid, precise, and efficient work.

Characteristics and details

- Heavy-duty design
- Slim construction without external cylinders
- Powerful, swift, and flexible working in very small spaces
- Amply dimensioned 7-channel rotary feedthrough with 90 L/min for use with complex hydraulic attachments even without sandwich
- Integrated quick-change unit for swift and safe changing of various attachments without the need to leave the vehicle
- Completely encapsulated system
- Innovative pivoting concept with radial piston motor

Innovative pivoting concept with radial piston motor

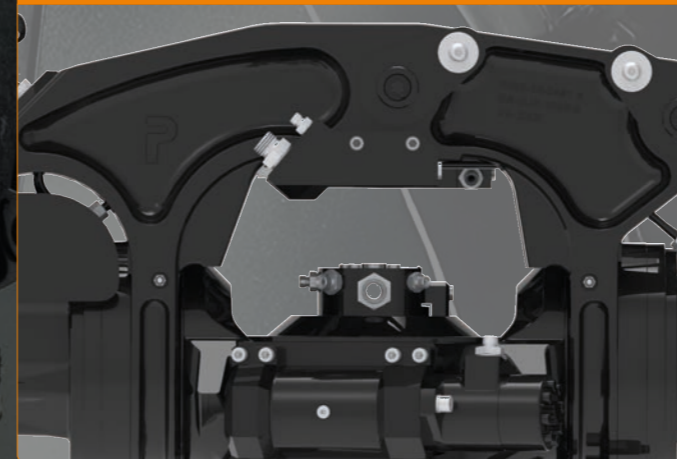

Amply dimensioned 7-channel rotary feedthrough

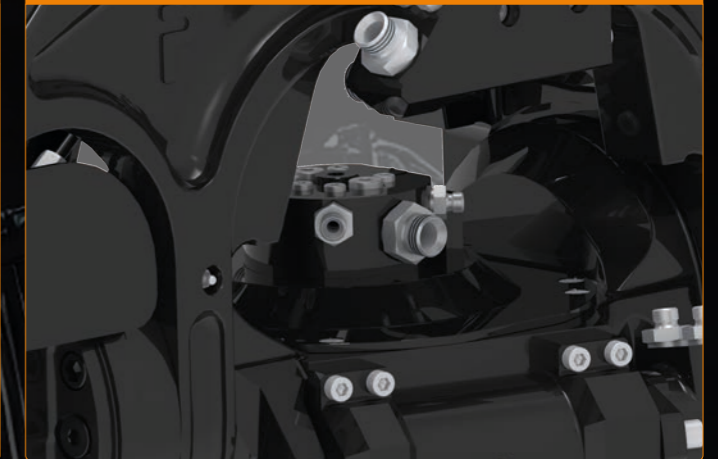

3-ton load hook



Plug-in couplings for attachments

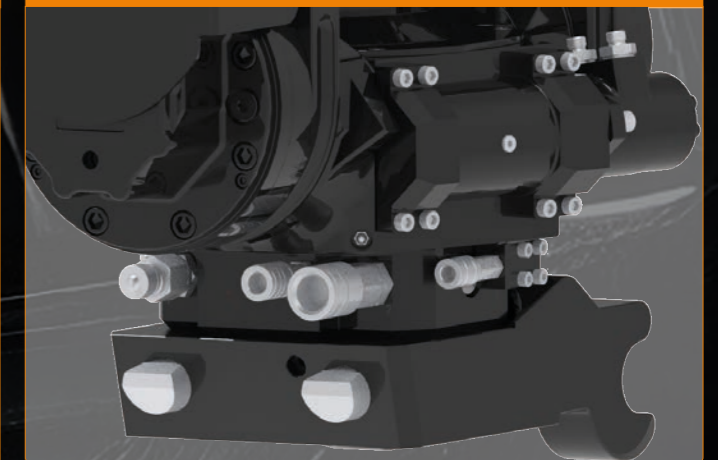

2 x 50° pivoting angle

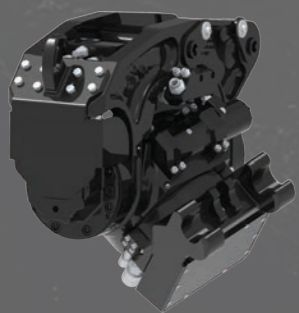

Infinite rotation

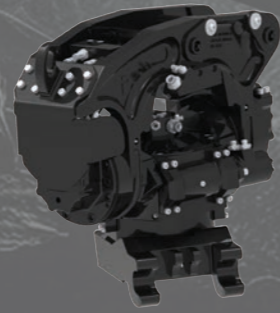

Only 5 lubrication service points

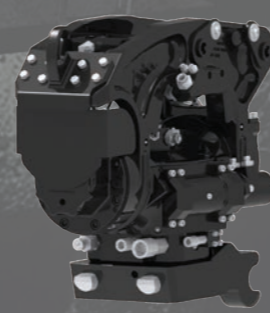

Slim, rugged design



Protected pivot drives and lines

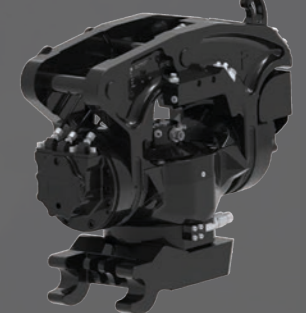

TECHNICAL DATA

Pister Tiltrotator PT

PT L

Excavator category	7 - 12 t
Quick-change unit (QCU)	Different makes available
Sensor scanning QCU	Optional
Pivoting angle	2 x 50°
Swing torque*	10 kNm
Rotational torque*	7 kNm
Max. tray width	1400 mm
Width	445 mm
Length	895 mm
Height	500 mm
Weight	ca. 385 kg incl. quick-change unit
Rotary feedthrough	7 channels first circuit (90 l/min*): G3/4 second circuit: G1/4 Leak oil connection: G3/8 2 plug-in couplings to QCU optional current feedthrough
load hook	3 t

Subject to technical modifications
* approximate values: based on volume flow and pressure of equipment

75-007-050

MANUFACTURER



T +49 (0) 72 22 – 50 02 – 0
info@pister-gmbh.com
pister-gmbh.com
invasion-baustelle.de

SALES



T +49 8304 30 999 30
info@hain-hydraulik.de
hain-hydraulik.de

FOLLOW US

